

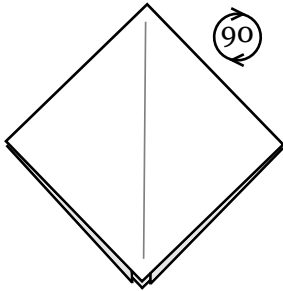

Open Tulip

© B. Domangue 2013

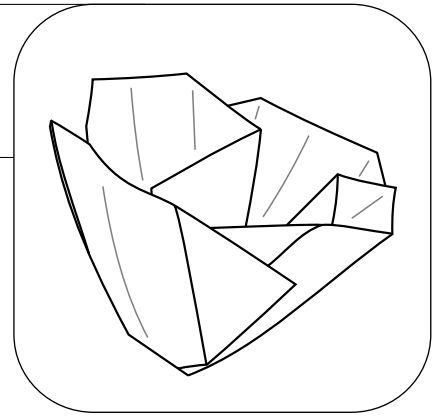

1. Begin with a square base. Rotate clockwise 90 degrees.

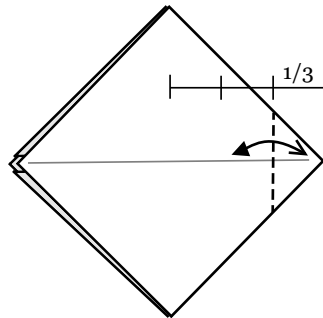

2. Measure 1/3 from point to center of model. Valley fold and unfold.

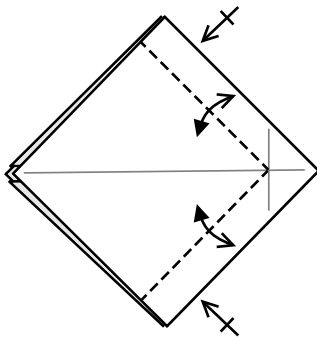

3. Valley fold and unfold parallel to edge. Repeat on opposite side.

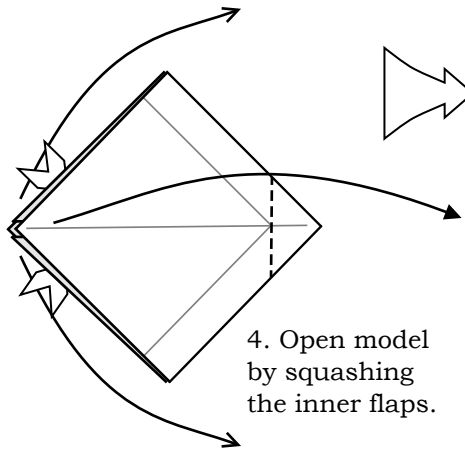

4. Open model by squashing the inner flaps.

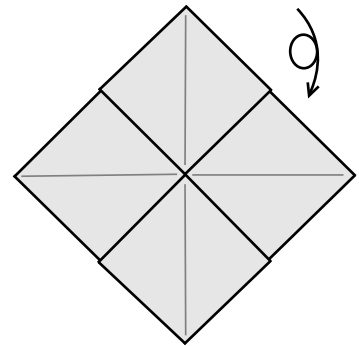

5. Flip the model over.

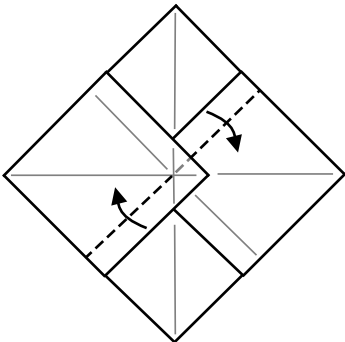

6. Valley fold.

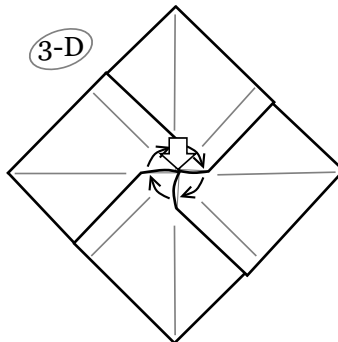

7. Squash point while twisting clockwise.

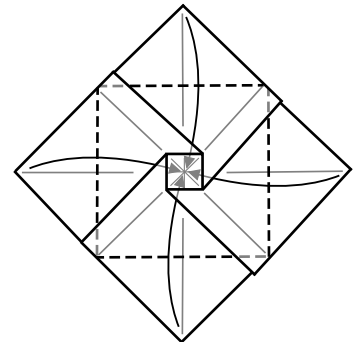

8. Valley fold to center.

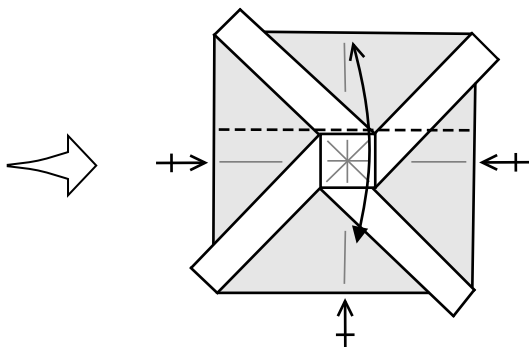

9. Valley fold and unfold. Repeat on other three sides.

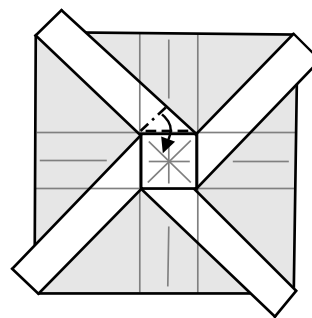

10. Valley fold while lifting corner up. Mountain fold edge along diagonal center crease.

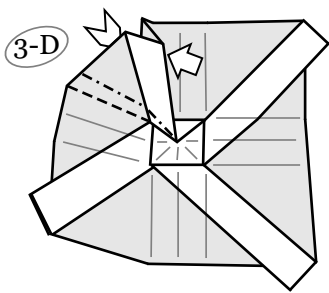

11. Open and squash.

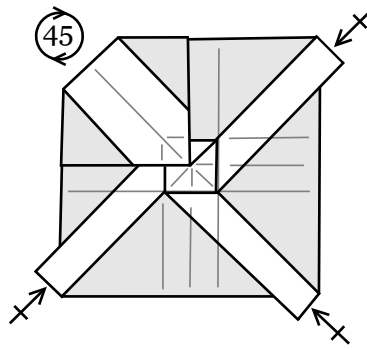

12. Repeat steps 10 - 11 on other three sides. Then, rotate model 45 degrees.

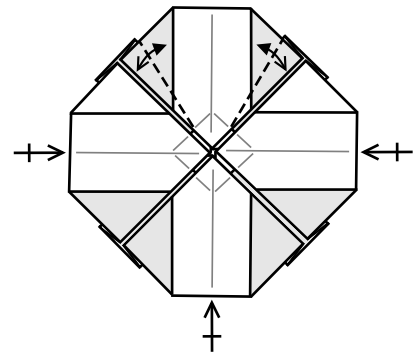

13. Valley fold and unfold. Repeat on other three sides.

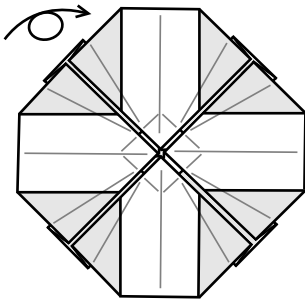

14. Flip the model over.

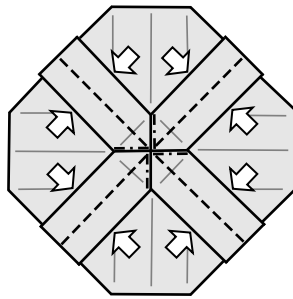

15. Pinch to reinforce valley fold creases and raise mountain folds from center.

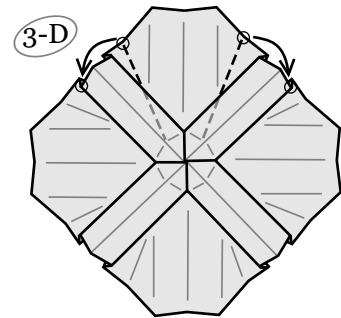

16. Shift the pleat by valley folding (along existing crease) and tucking edge into crevice (circled point to circle point).

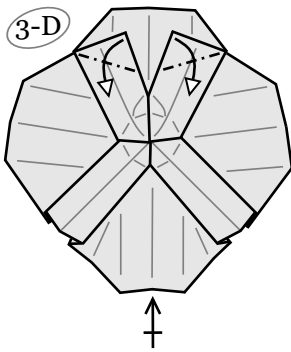

17. Mountain fold to lock in place. Then repeat steps 16 - 17 on opposite side.

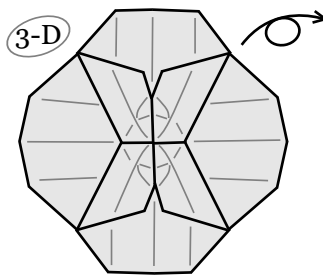

18. Flip the model over.

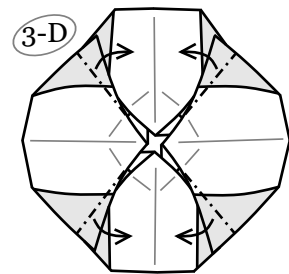

19. Shift the pleat by mountain folding (along existing crease) and pulling across the layer underneath.

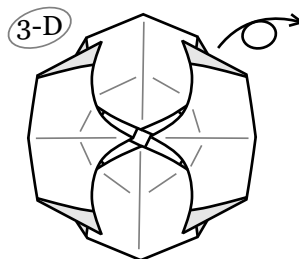

20. Flip the model over. Some shaping of the layers may be necessary for the model to hold its overall shape.



21. Tulip complete.